

并联机器人——

志华系列—WSC-1000D

Parallel Robots—ZhiHuaSeries

行程范围 Technical Specifications

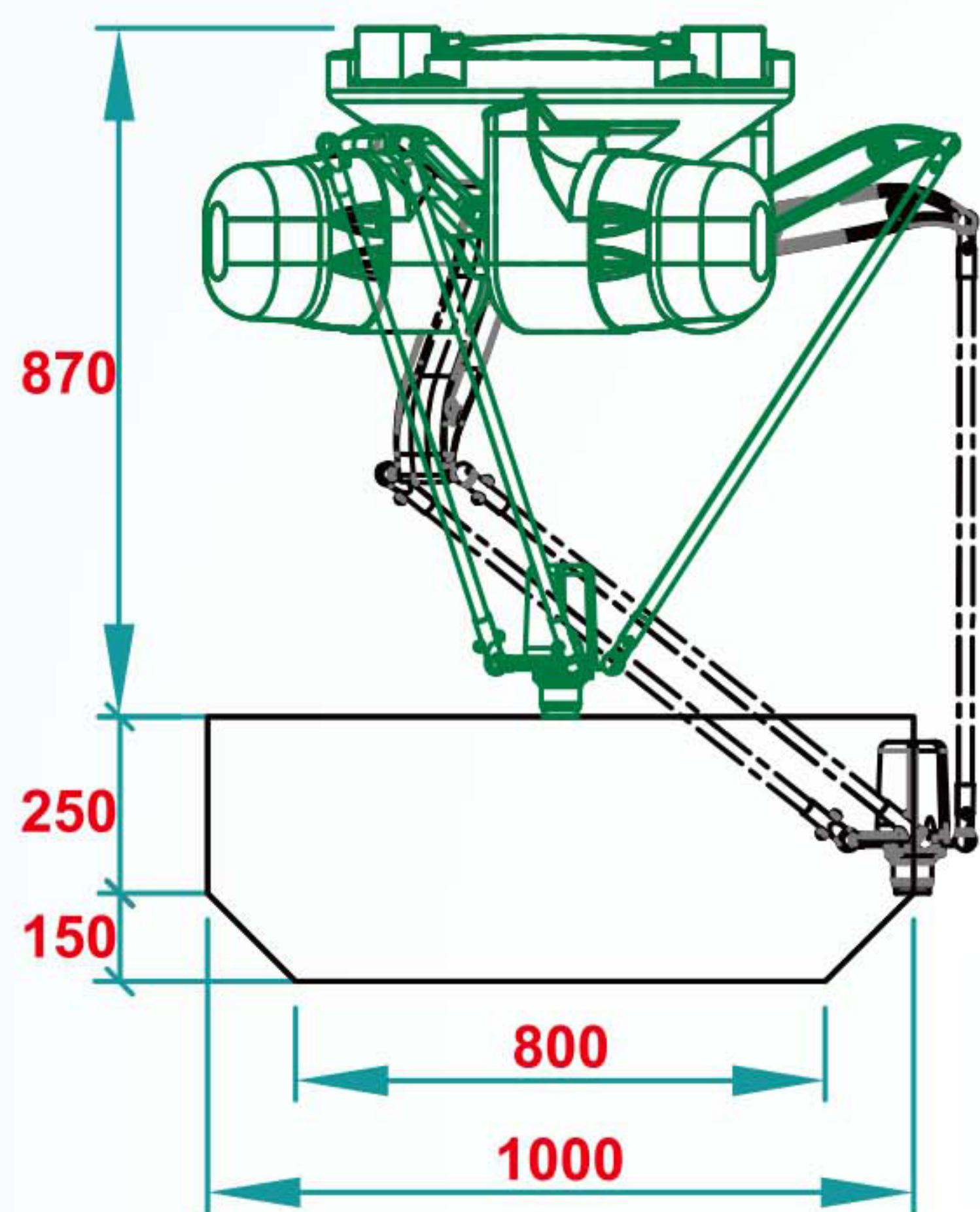

运动范围
Operating Range

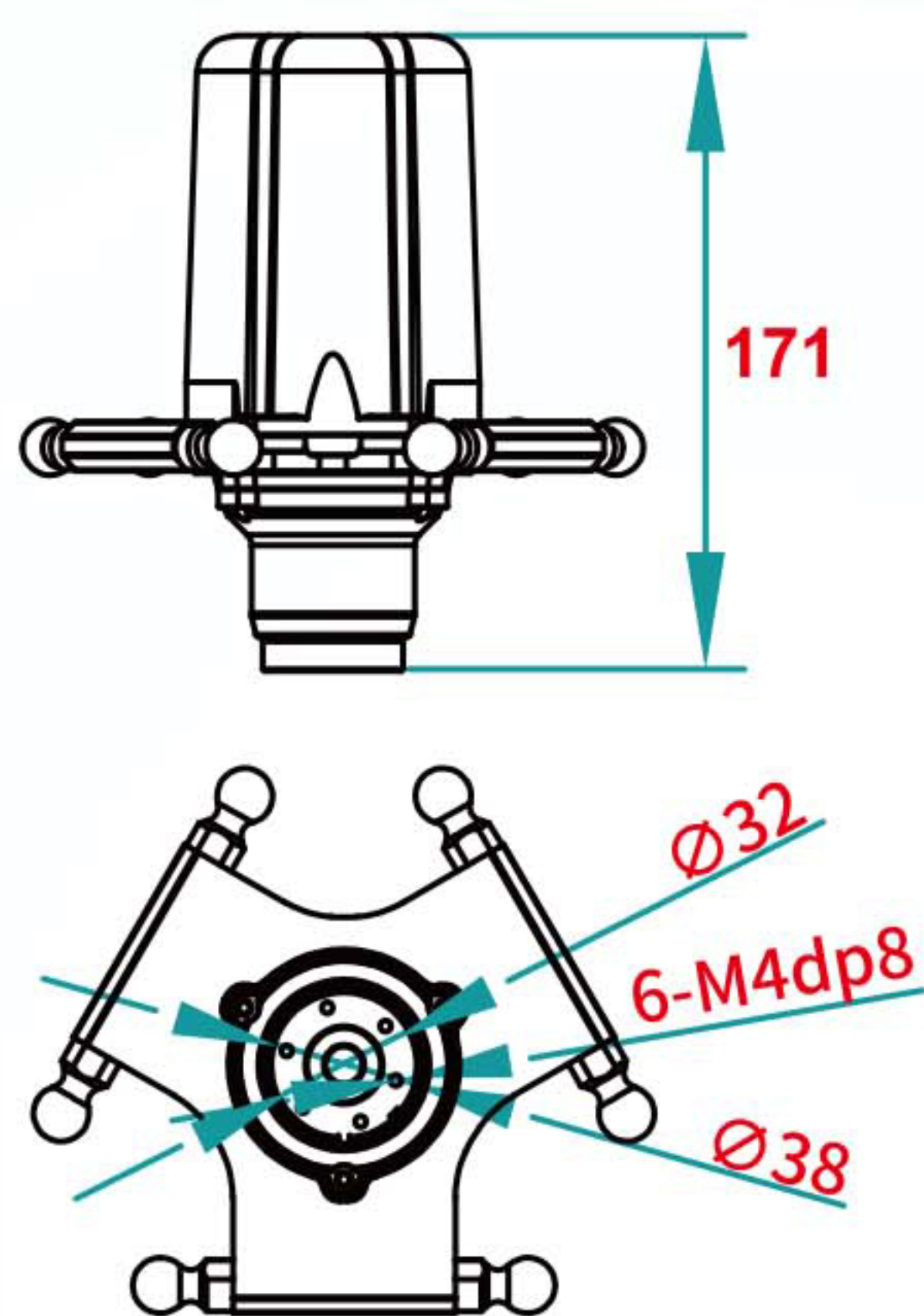

末端法兰
End Flange

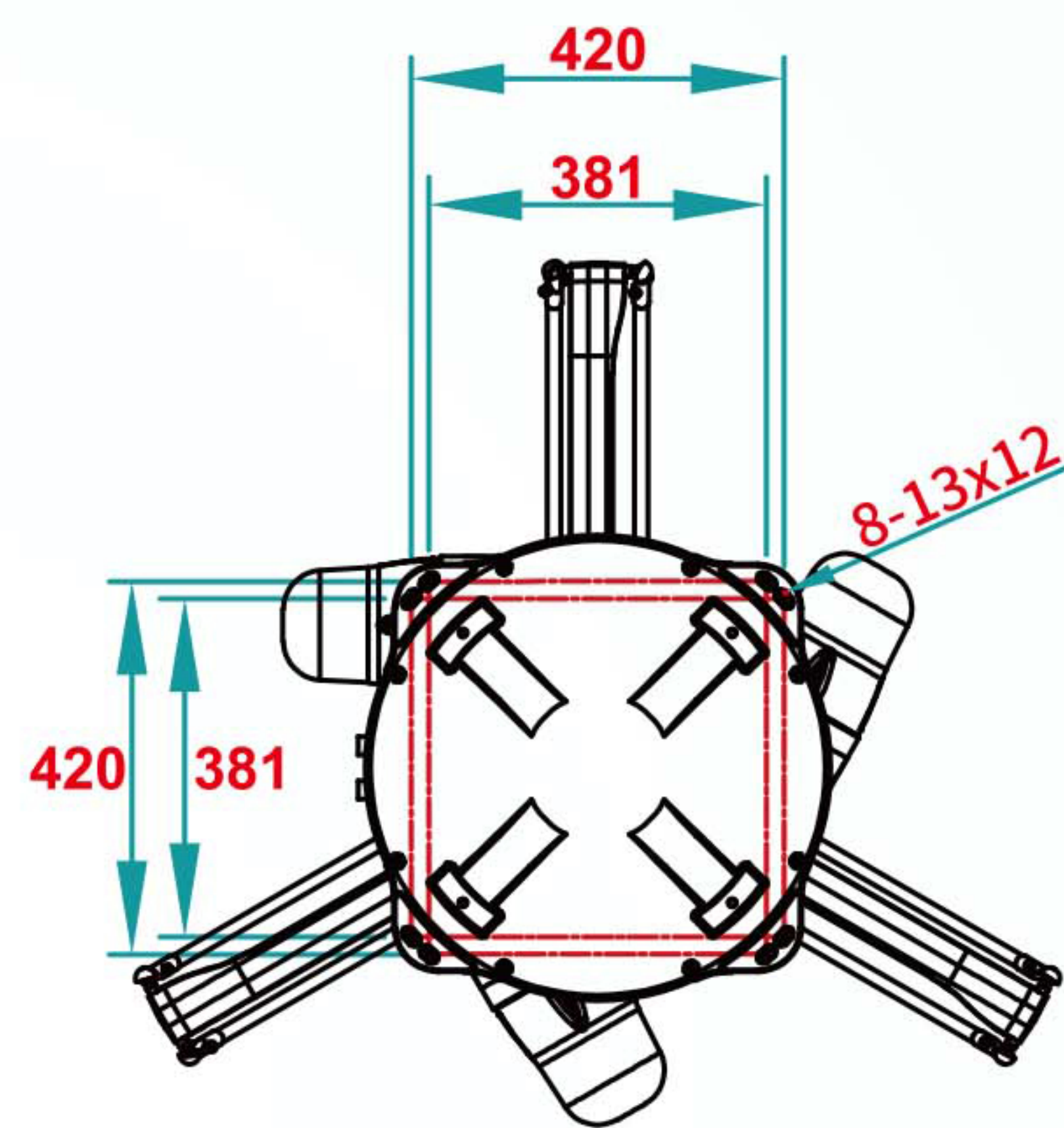

安装基座
Mounting Base

性能参数 Performance parameters

型号 Model	WSC-1000D-L3	WSC-1000D-L8	WSC-1000D-L12
动作自由度 Power Rating	四轴	四轴	四轴
最大负载 (kg) Max Load	3kg	8kg	12kg
标准循环时间 (s) Standard cycle time	0.4秒/节拍 (25/305/25mm)	0.4秒/节拍 (25/305/25mm)	0.4秒/节拍 (25/305/25mm)
重复定位精度 (mm) Repeat positioning accuracy	±0.05mm	±0.05mm	±0.05mm
角度定位精度 Angular Positioning Accuracy	0.05°	0.05°	0.05°
电源 Power	220V	220V	220V
额定功率 Power Rating	2.5kw	3.5kw	5kw
噪音水平 Noise Level	<75db	<75db	<75db
防护等级 Protection Level	IP54	IP54	IP54
驱动方式 Motor Method	Ac伺服驱动 Servo drives	Ac伺服驱动 Servo drives	Ac伺服驱动 Servo drives
示教器 Demonstrator	7寸示教器 7 inch	7寸示教器 7 inch	7寸示教器 7 inch
视觉定位模组 Vision Positioning Module	选配 (130w相机、镜头、光源)	选配 (130w相机、镜头、光源)	选配 (130w相机、镜头、光源)
运动指令 Operating Instructions	PTP、LINE、PICK、PLACE	PTP、LINE、PICK、PLACE	PTP、LINE、PICK、PLACE
安装方式 Installation Method	倒置式 Inverted	倒置式 Inverted	倒置式 Inverted
机器人重量 Robot Weight	72kg	72kg	72kg